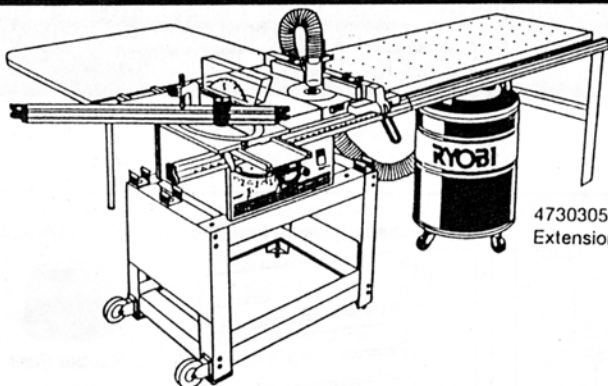

RYOBI**OWNER'S OPERATING MANUAL****#4730305 LEG SET****(FOR USE WITH THE BT3000 10" TABLE SAW)**

4730305
Extension Table Leg Set

CONGRATULATIONS AND THANK YOU FOR BUYING THIS RYOBI LEG SET

Your new #4730305 LEG SET has been designed for use with the RYOBI BT3000 10" Precision Woodcutting System. It has been engineered and manufactured to Ryobi's high standards for operator safety, quality and dependability, and ease of operation. The legs can be quickly mounted to the rails of your BT3000 10" Table Saw, or the Air Floation/Vacuum Clamp Table. Properly cared for, it will provide years of dependable, trouble-free performance.

RULES FOR SAFE OPERATION

- 1. READ THESE INSTRUCTIONS THOROUGHLY** before assembling or using this leg set.
- 2. READ THE INSTRUCTIONS AND RULES FOR SAFE OPERATION FOR THE BT3000 TABLE SAW** before operating your saw with this leg set.
- 3. KEEP ASSEMBLY AREA AND WORK AREA CLEAN.** Cluttered areas and benches invite accidents.
- 4. ALWAYS WEAR SAFETY GLASSES.** Everyday eyeglasses have only impact-resistant lenses they are NOT safety glasses.
- 5. DO NOT USE THIS PRODUCT WITH OTHER EQUIPMENT OR FOR OTHER PURPOSES.**
- 6. ALWAYS DISCONNECT SAW FROM POWER SUPPLY BEFORE ASSEMBLING THIS LEG SET.** Make sure switch is off when connecting saw to power supply.
- 7. DO NOT STAND ON THE SAW OR ANY ACCESSORY.**

Save This Manual For Future Reference

TOOLS NEEDED

Tools needed for assembly of this table are a 1/4", 1/2" and 5/16" socket wrench.

UNPACKING AND CHECKING PARTS

Separate all parts from packing materials. Check your parts with the parts list shown on this page. Refer to Figure 1 if you are unsure about the description of any part. If any parts are missing, delay your assembly of this Leg Set until you have obtained the missing part(s).

WARNING: ATTEMPTING TO ASSEMBLE THE LEG SET OR TO USE IN ANY WAY WITHOUT OBTAINING ANY MISSING PARTS AND INSTALLING THEM CORRECTLY COULD RESULT IN AN ACCIDENT RESULTING IN POSSIBLE SERIOUS INJURY.

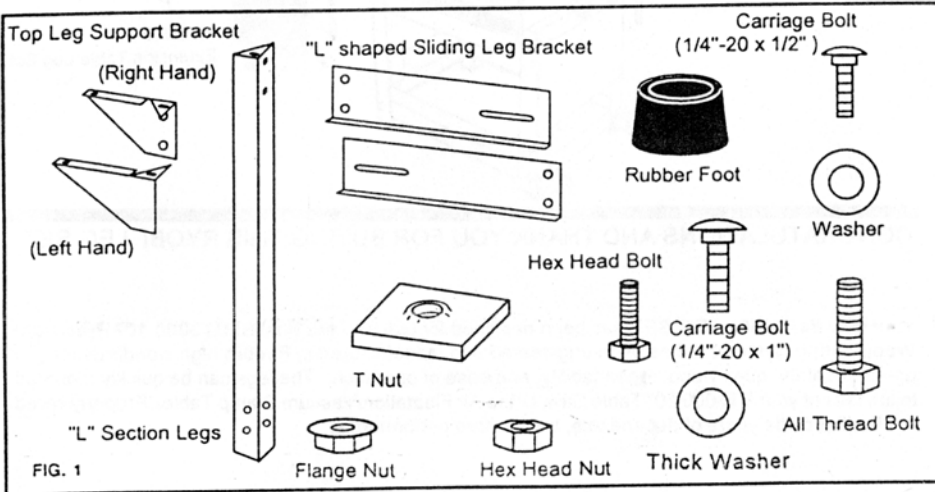

LIST OF LOOSE PARTS

Your #4730305 Leg Set includes the following parts:

DESCRIPTION	QUANTITY	DESCRIPTION	QUANTITY
"L" shaped sliding leg Bracket.....	2	Hex Head Nut (1/2"-13")	2
"L" Section Legs	2	Rubber Foot	2
Top Leg Support Bracket (Left Hand) ...	1	Carriage Bolt (1/4"-20 x 1")	4
Top Leg Support Bracket (Right Hand) 1		Flange Nut (1/4"-20).....	13
Carriage Bolt (1/4"-20 x 1/2")	9	T Nut.....	4
Washer (5/16")	9	Hex Head Bolt (5/16"-18 x 1/2")	4
All Thread Bolt (1/2"-13 x 3")	2	Thick Washer.....	4

ASSEMBLY

Read these instructions completely before beginning assembly of this table.

Leg Set

TO ASSEMBLE THE LEG KIT

1. Insert one 1/4" -20 x 1/2" carriage bolt through the sliding leg brackets and tighten lightly utilizing one 1/4" nut and one 5/16" washer. See Figure #2.
2. Utilizing four 1/4" - 20 x 1/2" carriage bolts, nuts and washers, assemble the sliding leg bracket to the "L" section legs as shown. See Figure #2.
3. Utilizing four 1/4" - 20 x 1/2" carriage bolts, nuts and washers, assemble the left and right hand leg support brackets to the "L" section legs. See figure #2.
4. Insert the two 1/2" x 3" all thread bolts into the bottom of each "L" section leg. Secure the bolts with the 1/2" nuts provided. Adjust the bolts to the correct height, insert the rubber feet. See Figure #2.

TO ASSEMBLE THE LEGS TO THE OPTIONAL AIR FLOATATION / VACUUM CLAMP TABLE (not supplied)

1. Place four carriage bolts (1/4"-20 x 1") into the top of the table. Mount the leg assembly on the underside of the table using the flange nuts provided (1/4"-20). Do not over tighten the flange nuts or you may damage the table by pulling the bolts through. Tighten the sliding leg bracket bolt. See Figure #3
2. For use with the Air Floatation / Vacuum Clamp Table independent of the BT3000 table saw repeat step #1 for the other end of the table. For additional support cut a (3/4" X 21 1/2" X 39 1/2") plywood shelf and mount between the legs. See Figure #4

TO ASSEMBLE THE LEGS TO THE OPTIONAL BT3000 WIDE TABLE KIT (not included)

1. Slide the T-Nuts into the bottom of the rails as shown. Insert the hex head bolt (5/16"-18 x 1/2") and thick washer through the bottom of the leg hole. Screw the bolt into the T-Nut. Secure the bolt firmly. Tighten the sliding leg bracket bolt. See Figure #5.

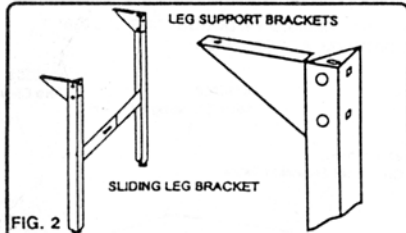

FIG. 2

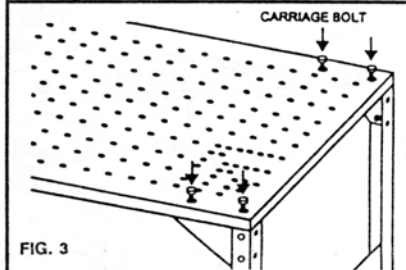

FIG. 3

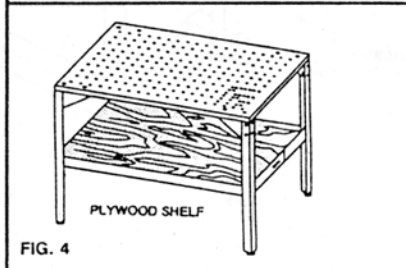

FIG. 4

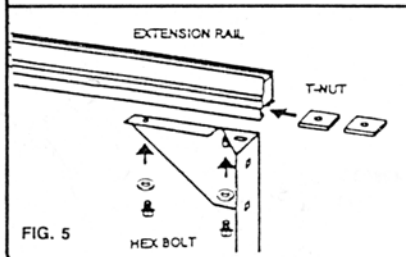
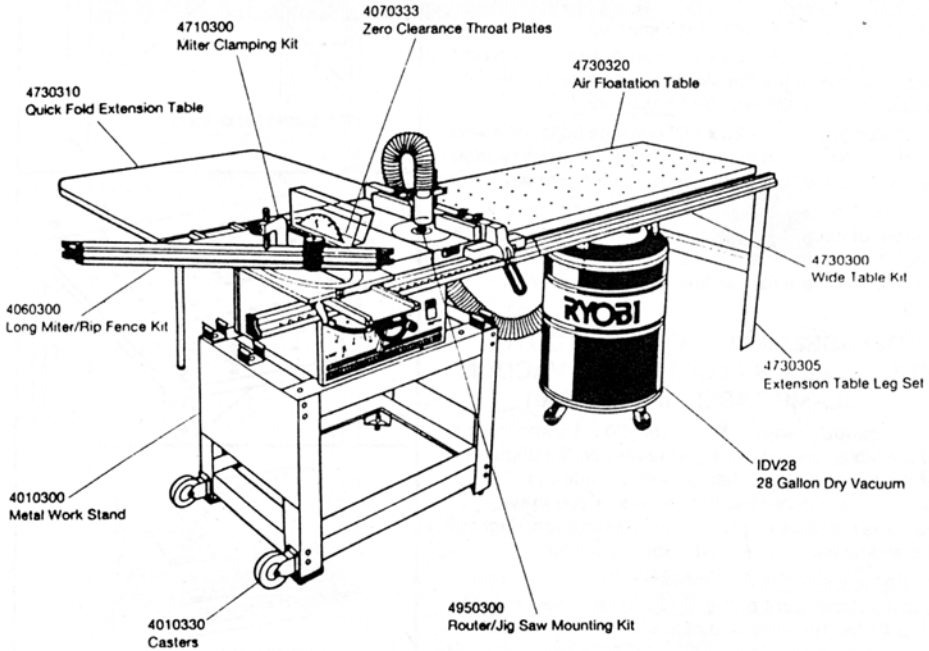

FIG. 5



OWNER'S OPERATING MANUAL
#4730305 LEG KIT
(FOR USE WITH THE BT3000 TABLE SAW)

BT3000 10" PRECISION WOODCUTTING SYSTEM
AND OPTIONAL ACCESSORIES



OTHER OPTIONAL ACCESSORIES

Dado Throat Plate	4070330
Dust Bag	4070300
10" Carbide-Tipped Blades	
24T Rip	4650324
36T General Purpose	4650300
40T Crosscut	4650340
80T Crosscut-Fine Finish	4650360
Extra Accessory Table	4080300
Table Clamp Kit	4080330
Stop Block Kit	4060330
User Kit	4050300
6 1/2" Adjustable Dado	4658718

4980305

8-93

RYOBI AMERICA CORP.

5201 Pearman Dairy Road Anderson SC 29625-8950
Post Office Box 1207 Anderson SC 29622-1207
Phone 1-800-323-4615

Printed in U.S.A.